

EMULA

Dati Tecnici - Datasheet

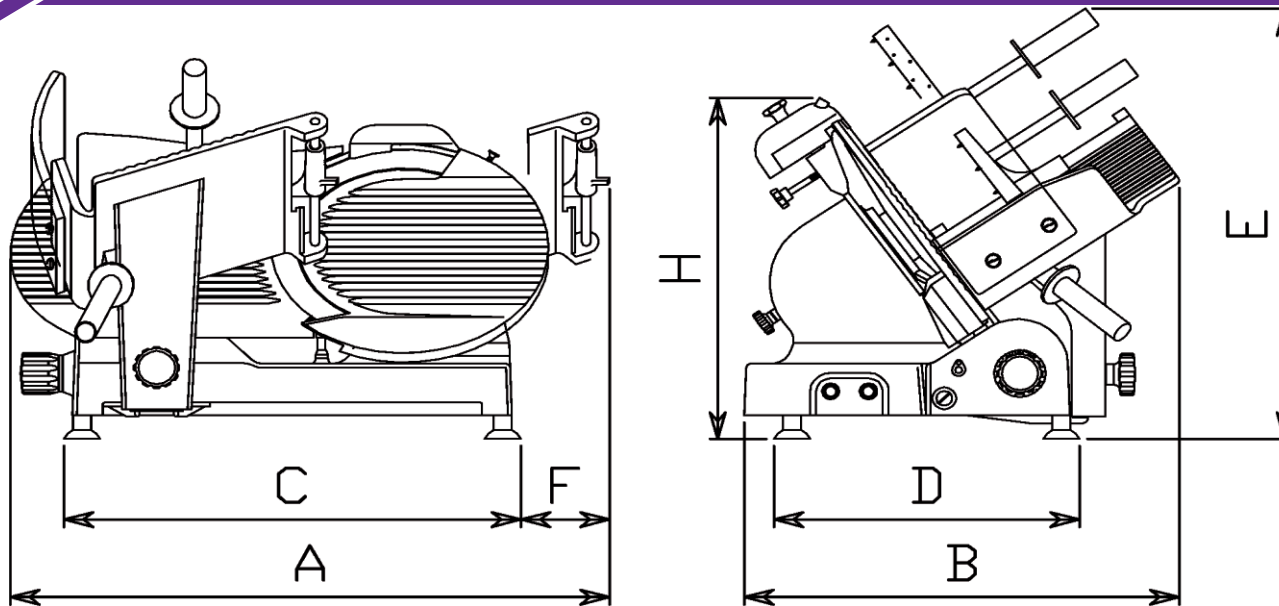

Modello Model	Diametro lama Blade diameter mm/inch	Giri Lama Blade revolution rpm	Motore monofase 230V/50Hz Single-phase Motor W/HP	Motore trifase 400V/50Hz Three-phase Motor W/HP	Corsa carrello Run of carriage mm	Spessore taglio Cut thickness mm	Capacità di taglio tondo Round cut capacity mm	Capacità di taglio HxL Cut capacity HxW mm	Peso netto Net weight kg	Dimensioni imballo Shipping mm	Peso lordo Gross weight kg	Dimensioni (mm) Dimension (mm)						
												A	B	C	D	E	F	H
R-TGDV350	350/13,8	210	370-0,50	370-0,50	380	0-15	250	200x300	47,5	80x70xh66+12	53+6	770	565	600	420	600	60	500
R-TGDV370	370/14,6	210	370-0,50	370-0,50	380	0-16	260	210x300	47,5	80x70xh66+12	53+6	770	565	600	420	600	60	500
R-TGDVI350	350/13,8	215	370-0,50	370-0,50	380	0-15	250	200x300	47,5	80x70xh66+12	53+6	770	565	600	420	600	60	500