

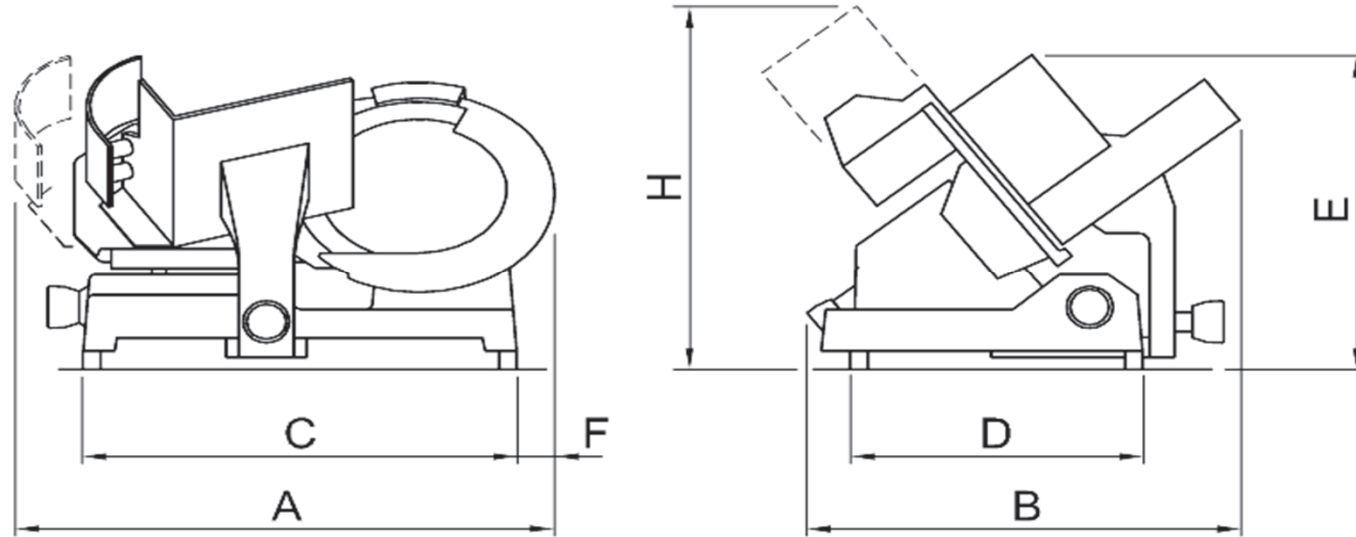

Affettatrici: S-TGC250 / S-TGC275 / S-TGC300

Dati Tecnici - Datasheet



Modello Model	Diametro lama Blade diameter mm/inch	Giri Lama Blade revolution rpm	Motore monofase 230V/50Hz Single-phase Motor W/HP	Motore trifase 400V/50Hz Three-phase Motor W/HP	Corsa carrello Run of carriage mm	Spessore taglio Cut thickness mm	Capacità di taglio tondo Round cut capacity mm	Capacità di taglio HxL Cut capacity HxW mm	Peso netto Net weight kg	Dimensioni imballo Shipping mm	Peso lordo Gross weight kg	A	B	C	D	E	F	H
S-TGC250	250/9,8	270	180-0,25	-	295	0 - 14	165	170x240	19	74x68xh57+12	24+6	625	510	470	330	375	90	445
S-TGC275	275/10,8	270	180-0,25	-	295	0 - 14	190	175x240	20	74x68xh57+12	25+6	625	510	470	330	385	90	455
S-TGC300	300/11,8	270	180-0,25	-	295	0 - 14	205	180x250	21	74x68xh57+12	26+6	625	510	470	330	405	90	470