

EMULA

Affettatrici automatiche : T-TGN300 / T-TGN330

Dati Tecnici - Datasheet

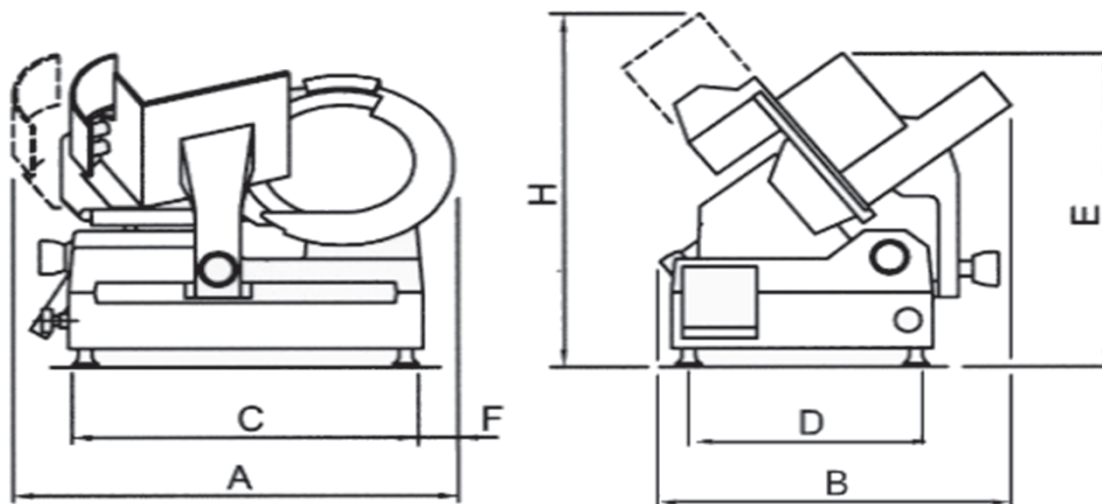

Modello <i>Model</i>	Diametro lama <i>Blade diameter</i>	Giri Lama <i>Blade revolution</i>	Motore monofase 230V/50Hz <i>Single-phase Motor</i>	Motore trifase 400V/50Hz <i>Three-phase Motor</i>	Corsa carrello <i>Run of carriage</i>	Spessore taglio <i>Cut thickness</i>	Capacità di taglio tondo <i>Round cut capacity</i>	Capacità di taglio HxL <i>Cut capacity HxW</i>	Peso netto <i>Net weight</i>	Dimensioni imballo <i>Shipping</i>	Peso lordo <i>Gross weight</i>	A	B	C	D	E	F	H
T-TGN300	300/11,8	275	180-0,25	180-0,25	315	0 - 14	225	190x260	41	74x68xh57+12	47+6	705	565	456	296	530	80	600
T-TGN330	330/13,0	275	180-0,25	180-0,25	315	0 - 14	235	195x260	43	74x68xh57+12	48+6	705	565	456	296	545	80	615