

EMULA

Dati Tecnici - Datasheet

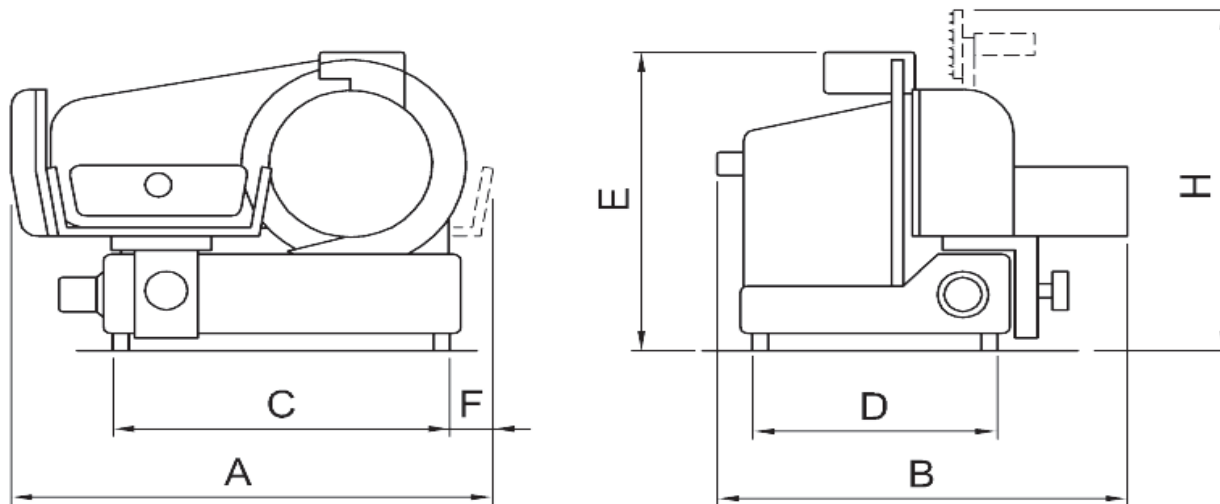

Modello Model	Diametro lama Blade diameter mm/inch	Giri Lama Blade revolution rpm	Motore monofase 230V/50Hz Single-phase Motor W/HP	Motore trifase 400V/50Hz Three-phase Motor W/HP	Corsa carrello Run of carriage mm	Spessore taglio Cut thickness mm	Capacità di taglio tondo Round cut capacity mm	Capacità di taglio HxL Cut capacity HxW mm	Peso netto Net weight kg	Dimensioni imballo Shipping mm	Peso lordo Gross weight kg	Dimensioni (mm) Dimension (mm)							
												A	B	C	D	E	F	H	
R-TCN350	350/13,8	215	400-0,55	400-0,55	370	0 - 23	250	250x325	53	80x72xh65+12	62+6	810	670	620	420	590	100	670	
R-TCN370	370/14,6	215	400-0,55	400-0,55	370	0 - 23	265	265x325	54	80x72xh65+12	63+6	810	670	620	420	590	100	670	
R-TCN390	390/15,4	215	400-0,55	400-0,55	370	0 - 23	270	270x325	55	80x72xh65+12	64+6	815	670	620	420	600	105	675	